

MS2650

Mariner Kit for use with HP Elite 800 G9 Tower PC
(Desktop configuration)



The HP Elite 800 G9 Tower (TWR) PC is marine type approved by most of the major international marine Classification Societies when it is installed in conjunction with our Mariner Kit MS2650.

The MS2650 Mariner Kit is designed to fit onto any horizontal surface and affords protection against the effects of vibration and shock experienced in the offshore marine environment and has been tested against IACS Unified Requirement E10 and the relevant sections of IEC60945 (see below right for test details).

This type approved combination of hardware and Mariner Kit can be used as the platform for your critical navigation, control, loading and general purpose applications (please check individual type approval certificates for any restrictions).

**“Steer the right course
with Mariner Systems”**



PRODUCT FEATURES

- ◆ Take your work to a new level of productivity with the HP Elite 800 G9 Tower PC
- ◆ Able to handle complex programs, this high performance, expandable, and highly secure PC is ready for the most demanding workloads
- ◆ Intel® Q670 chipset supporting 12th Generation Intel® Core™ processors, featuring integrated Intel® UHD Graphics and Intel® vPro® Technology (available with Core™ i3, Core™ i5 and Core™ i7 processors)
- ◆ **Internal Bays:** 2 x Slim Optical Disc Drive (ODD or removable storage); 2 x 3.5" Internal Storage Drive; 1 x SD Card Reader (optional)
- ◆ **Internal Ports:** 4 x PCI Express (full-height); 4 x SATA ports; 2 x M.2 2280 (for storage)
- ◆ **USB Ports:** 10 x Type-A USB ports (4 front, 6 rear); 1 x USB Type-C USB port (front)
- ◆ **Graphics Ports:** 2 x Dual-Mode DisplayPort™ 1.4a; 1 x HDMI port 1.4 (rear)
- ◆ **Flex I/O Port (optional – choice of one):** 1 x Dual Type-A SuperSpeed USB 5Gbps; 1 x Type-C SuperSpeed USB 10Gbps; 1 x Thunderbolt™ 3.0 with USB 4.0; 1 x DisplayPort™ 1.4a; 1 x HDMI 2.1; 1 x VGA; 1 x RS-232 Serial port (rear)
- ◆ **Network Port:** 1 x RJ45 Network connector (rear)
- ◆ ENERGY STAR® certified and EPEAT® registered where applicable
- ◆ CCC, CECP and SEPA certified (where applicable)
- ◆ Compliant with the Restrictions of Hazardous Substances (RoHS) Directive – 2011/65/EC
- ◆ Compliant with the Waste Electrical and Electronic Equipment (WEEE) Directive – 2002/96/EC
- ◆ PC chassis and all internal components and modules are manufactured with low halogen content
- ◆ One-year limited warranty on parts and labour as standard

This Mariner Systems solution is tested against the consolidated, 'worst-case' requirements of all the following major international marine Classification Societies:

ABS, BV, CCS, ClassNK, DNV, KR, LR, PRS, RINA

Tests included within the test programme are as follows:

- > Vibration, Shock, Static and Dynamic Inclination
- > Dry & Damp Heat, Low Temperature
- > Acoustic Noise, Compass Safe Distance
- > High Voltage, Power Supply Variation & Power Supply Failure
- > Conducted LF & RF, Electromagnetic Field
- > Radiated & Conducted Emissions, Electrostatic Discharge
- > Insulation Resistance, Burst / Fast Transients
- > Surge Immunity, Access to Dangerous Voltages

MS2650

Mariner Kit for use with HP Elite 800 G9 Tower PC (Desktop configuration)

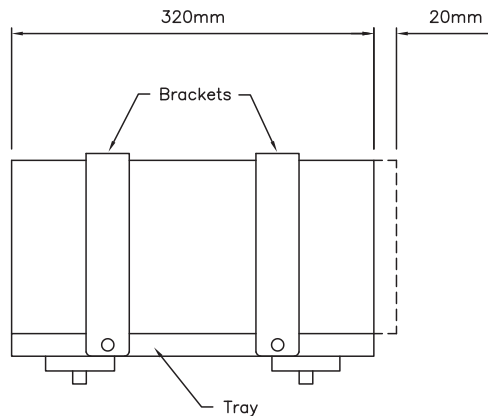
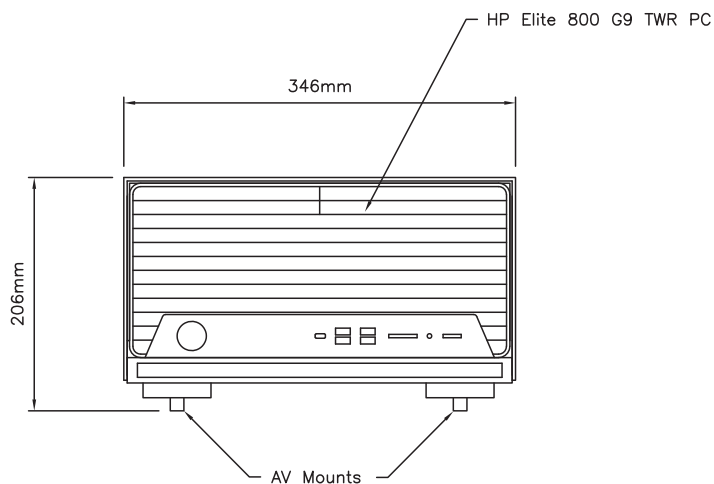

Mariner Systems (UK) Limited

Oaklands Park • Wokingham • Berkshire • RG41 2FD • United Kingdom

Telephone: +44 (0) 118 979 6020 • sales@marinersystems.com

www.marinersystems.com

OPERATING GUIDELINES

Although all of our solutions are tested against extreme environmental conditions for the purposes of marine type approval, installation should take into account the following guidelines:

- Keep the computer away from excessive moisture, direct sunlight and the extremes of heat and cold. Wherever possible, ensure that the unit is operated within the manufacturer's recommended operating range:

	Operating	Non-Operating
Temperature	+10° to +35°C (+50° to +95°F)	-30° to +65°C (-22° to +149°F)
Humidity	10% to 90% (non-condensing)	5% to 95% (non-condensing)

- Leave a 10.2 cm (4-inch) clearance on all vented sides of the computer to permit the required airflow
- Never restrict airflow into the computer by blocking any vents or air intakes
- Occasionally clean the air vents on all vented sides of the computer
- If the computer is to be operated within a separate enclosure, intake and exhaust ventilation must be provided on the enclosure, and the same operating guidelines listed above will still apply

By following these guidelines, you will maximise the life of your computer and minimise service costs.

STATISTICS

Overall Fitted Dimensions	346mm (w) x 206mm (h) x 340mm (d)
Weight (Mariner Kit only)	2.1 kg
Weight (including hardware)	8.3 kg (exact weight depends upon configuration)
Chipset	Intel® Q670
Processor	Intel® 12 th Generation Core™ i7, i5 & i3
Memory	Up to 128 GB DDR5-4800 DIMM
Storage	500 GB to 2 TB 3.5-inch SATA (7,200 rpm); 500 GB to 1 TB 2.5-inch SATA (7,200 rpm); 500 GB 2.5-inch SATA SED Opal 2 (7,200 rpm); 256 GB to 1 TB M.2 2280 PCIe NVMe SSD; 256 GB to 2 TB M.2 2280 PCIe NVMe TLC SSD
Keyboard	HP USB Keyboard
Mouse	HP USB Mouse
Networking (integrated)	Intel® I219LM GbE LOM
Graphics (integrated)	Intel® UHD Graphics
Optical Storage	HP 9.5mm Slim DVD-ROM; HP 9.5mm Slim DVD Writer
Operating System	Windows 11; Windows 10; FreeDOS
Expansion Slot	2 x full-height PCIe x1 (v3.0) slots; 1 x full-height PCIe x16 (v4.0) slot; 1 x full-height PCIe x16 (v3.0) slot (wired as a x4)
USB Support	3 x Type-A USB 2.0 (rear); 3 x Type-A USB 3.2 Gen 1 (rear); 4 x Type-A USB 3.2 Gen 2 (front); 1 x Type-C® USB 3.2 Gen 2x2 (front)
Rear I/O	2 x DisplayPort™ 1.4a; 1 x HDMI 1.4; 1 x RJ-45 Network connector
Operating Voltage Range	90 ~ 264 Vac